



GLYCODUR®  
RB and RS

The GLYCODUR® RB and GLYCODUR® RS sliding bearings are based on the tried and tested GLYCODUR® sliding bearings. However, through the use of a bronze backing (RB) or stainless steel backing (RS), they offer optimum heat conductivity and resistance to corrosion.





**1**

**Sliding bearing material**

- 1.1 Composition page 4
- 1.2 Characteristics summary of GLYCODUR® materials page 6

**2**

**Dimension table**

- 2.1 Dimension table GLYCODUR® RB from page 7

**3**

**Dimension table**

- 3.1 Dimension table GLYCODUR® RS from page 9

**4**

**Applications**

- 4.1 Applications GLYCODUR® RB and GLYCODUR® RS page 10



# 1

## 1.1 Composition

Sliding bearing material

GLYCODUR® RB and GLYCODUR® RS compliment the proven lead free GLYCODUR® sliding bearings with an important new characteristic: they are corrosion resistant.

Whereas the GLYCODUR® sliding bearings have a copper plated steel backing (see also: GLYCODUR® sliding bearing catalogue), the GLYCODUR® RB and GLYCODUR® RS use different backing materials.



### GLYCODUR® RB

GLYCODUR® RB sliding bearings have a bronze backing which makes them corrosion resistant. At the same time they have particularly good heat

conductivity compared to GLYCODUR® F sliding bearings. If heat is generated by the application, it can be dissipated better through the bearing into the housing.



### GLYCODUR® RS

GLYCODUR® RS sliding bearings have a stainless steel backing, which is very corrosion resistant. They are suitable

for all applications where it is important to avoid corrosion (the food industry for instance).

## GLYCODUR® RB

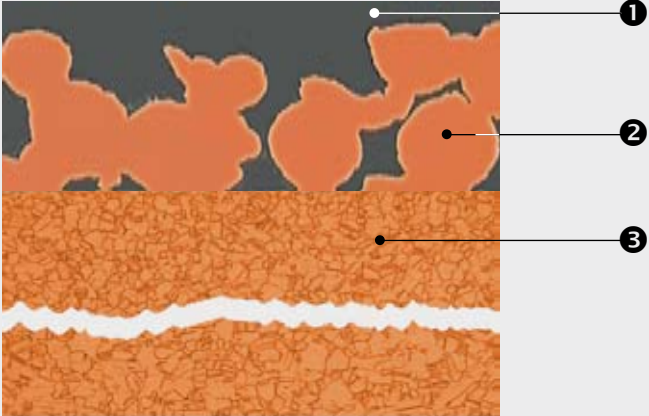

- ❶ Polytetrafluorethylene (PTFE) and additives
- ❷ Tin bronze
- ❸ Bronze backing

Figure 1.1.1 – Microsection GLYCODUR® RB

## GLYCODUR® RS

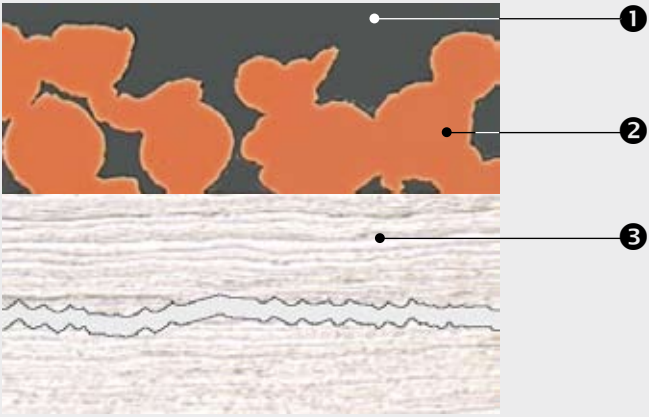

- ❶ Polytetrafluorethylene (PTFE) and additives
- ❷ Tin bronze
- ❸ Stainless steel backing

Figure 1.1.2 – Microsection GLYCODUR® RS

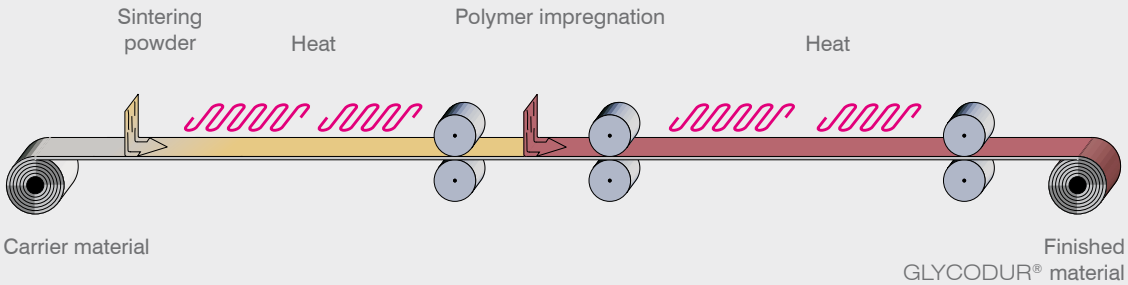

Figure 1.1.3 – Scheme production process

## 1.2 Characteristics summary of GLYCODUR® RB and GLYCODUR® RS

Properties	GLYCODUR® RB and GLYCODUR® RS
Construction	Bronze backing (RB) / stainless-steel backing (RS) with sintered layer of tin bronze. Pore filling and covering layer (5 to 30 μm) of PTFE with friction reducing additives
Permissible static specific bearing load	250 MPa
Permissible dynamic specific load	80 MPa
Maximum sliding velocity	2 m/s
Operating temperature	-200 to 260 °C
Coefficient of friction	0.03 to 0.25
Stick-slip	negligible
Wear layer thickness	0.2 mm
Lubrication	not required
Ability to support edge loads (e.g. resulting from misalignment)	fair
Ability to embed dirt and foreign particles	fair
Ability to carry alternating loads	good
Ability to accommodate linear movement	fair
Machining of sliding surface after mounting	calibration

Lubrication	Friction	Wear resistance	Load capacity
GLYCODUR® RB and GLYCODUR® RS			
Dry	●	●	●
Oil	●●●	●	●

- Limited applicable    ● Standard    ●● Superior    ●●● Excellent

**2.1** Dimension table GLYCODUR® RB bushings

Dimension			Mass	Designation
d	D	B		
mm	mm	mm	g	
<b>3</b>	4.5	3	0.20	<b>PG 030403 RB/4.5</b>
<b>4</b>	5.5	4	0.30	<b>PG 040504 RB/5.5</b>
	5.5	6	0.60	<b>PG 040506 RB/5.5</b>
<b>5</b>	7	5	0.70	<b>PG 050705 RB</b>
	7	8	1.10	<b>PG 050708 RB</b>
<b>6</b>	8	6	1.00	<b>PG 060806 RB</b>
	8	10	1.60	<b>PG 060810 RB</b>
<b>8</b>	10	8	1.70	<b>PG 081008 RB</b>
	10	12	2.50	<b>PG 081012 RB</b>
<b>10</b>	12	10	2.50	<b>PG 101210 RB</b>
	12	15	3.80	<b>PG 101215 RB</b>
	12	20	5.10	<b>PG 101220 RB</b>
<b>12</b>	14	10	3.00	<b>PG 121410 RB</b>
	14	12	3.60	<b>PG 121412 RB</b>
	14	15	4.50	<b>PG 121415 RB</b>
	14	25	7.60	<b>PG 121425 RB</b>
<b>14</b>	16	10	3.50	<b>PG 141610 RB</b>
	16	15	5.20	<b>PG 141615 RB</b>
	16	25	8.70	<b>PG 141625 RB</b>
<b>15</b>	17	15	5.60	<b>PG 151715 RB</b>
	17	25	9.30	<b>PG 151725 RB</b>
<b>16</b>	18	15	5.90	<b>PG 161815 RB</b>
	18	25	9.90	<b>PG 161825 RB</b>
<b>18</b>	20	20	8.80	<b>PG 182020 RB</b>
	20	25	11.00	<b>PG 182025 RB</b>
<b>20</b>	23	15	11.00	<b>PG 202315 RB</b>
	23	20	15.00	<b>PG 202320 RB</b>
	23	30	23.00	<b>PG 202330 RB</b>
<b>22</b>	25	15	12.00	<b>PG 222515 RB</b>
	25	20	16.00	<b>PG 222520 RB</b>
	25	30	25.00	<b>PG 222530 RB</b>

Dimension			Mass	Designation
d	D	B		
mm	mm	mm	g	
<b>24</b>	27	15	13.00	<b>PG 242715 RB</b>
	27	30	26.00	<b>PG 242730 RB</b>
<b>25</b>	28	15	14.00	<b>PG 252815 RB</b>
	28	25	23.00	<b>PG 252825 RB</b>
<b>30</b>	34	20	30.00	<b>PG 303420 RB</b>
	34	30	45.00	<b>PG 303430 RB</b>
	34	40	60.00	<b>PG 303440 RB</b>
<b>35</b>	39	20	34.00	<b>PG 353920 RB</b>
	39	30	52.00	<b>PG 353930 RB</b>
<b>40</b>	44	30	59.00	<b>PG 404430 RB</b>
	44	50	98.00	<b>PG 404450 RB</b>
<b>45</b>	50	30	83.00	<b>PG 455030 RB</b>
	50	50	140.00	<b>PG 455050 RB</b>
<b>50</b>	55	30	93.00	<b>PG 505530 RB</b>
	55	60	185.00	<b>PG 505560 RB</b>
<b>55</b>	60	40	135.00	<b>PG 556040 RB</b>
<b>60</b>	65	40	145.00	<b>PG 606540 RB</b>
	65	60	220.00	<b>PG 606560 RB</b>
	65	70	255.00	<b>PG 606570 RB</b>
<b>70</b>	75	50	210.00	<b>PG 707550 RB</b>
	75	70	300.00	<b>PG 707570 RB</b>
<b>75</b>	80	80	365.00	<b>PG 758080 RB</b>
<b>80</b>	85	60	290.00	<b>PG 808560 RB</b>
	85	100	485.00	<b>PG 8085100 RB</b>
<b>85</b>	90	100	510.00	<b>PG 8590100 RB</b>
<b>90</b>	95	60	325.00	<b>PG 909560 RB</b>
	95	100	540.00	<b>PG 9095100 RB</b>
<b>95</b>	100	100	570.00	<b>PG 95100100 RB</b>
<b>100</b>	105	60	360.00	<b>PG 10010560 RB</b>
	105	115	690.00	<b>PG 100105115 RB</b>

Delivery of special shapes and sizes on request if the batches are large enough to be economical.

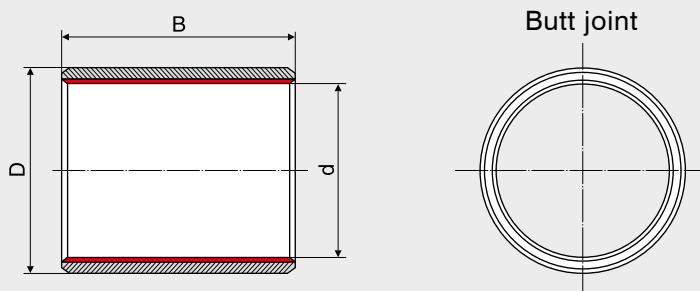

## 2.2 Dimension table GLYCODUR® RB flanged bushings

Dimension					Mass	Designation
d	D	D <sub>1</sub>	B	B <sub>1</sub>		
mm	mm	mm	mm	mm	g	
<b>5</b>	7	11.5	4	1	1.10	<b>PBG 050704 RB</b>
<b>6</b>	8	12	8	1	1.90	<b>PBG 060808 RB</b>
<b>8</b>	10	15	5.5	1	2.10	<b>PBG 081005.5 RB</b>
	10	15	9.5	1	2.90	<b>PBG 081009.5 RB</b>
<b>10</b>	12	18	7	1	3.10	<b>PBG 101207 RB</b>
	12	18	12	1	4.30	<b>PBG 101212 RB</b>
<b>12</b>	14	20	7	1	3.60	<b>PBG 121407 RB</b>
	14	20	9	1	4.20	<b>PBG 121409 RB</b>
	14	20	12	1	5.10	<b>PBG 121412 RB</b>
<b>14</b>	16	22	17	1	7.50	<b>PBG 141617 RB</b>
<b>15</b>	17	23	12	1	6.20	<b>PBG 151712 RB</b>
	17	23	17	1	7.60	<b>PBG 151717 RB</b>
<b>16</b>	18	24	12	1	6.20	<b>PBG 161812 RB</b>
	18	24	17	1	8.10	<b>PBG 161817 RB</b>
<b>18</b>	20	26	12	1	7.30	<b>PBG 182012 RB</b>
	20	26	22	1	12.00	<b>PBG 182022 RB</b>
<b>20</b>	23	30	11.5	1.5	13.00	<b>PBG 202311.5 RB</b>
	23	30	21.5	1.5	21.00	<b>PBG 202321.5 RB</b>
<b>25</b>	28	35	11.5	1.5	16.00	<b>PBG 252811.5 RB</b>
	28	35	21.5	1.5	25.00	<b>PBG 252821.5 RB</b>
<b>30</b>	34	42	16	2	35.00	<b>PBG 303416 RB</b>
	34	42	26	2	50.00	<b>PBG 303426 RB</b>
<b>35</b>	39	47	26	2	61.00	<b>PBG 353926 RB</b>

Delivery of special shapes and sizes on request if the batches are large enough to be economical.

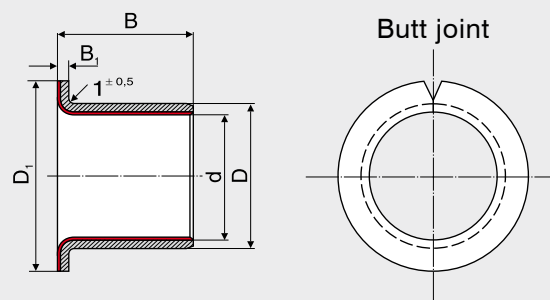

**3.1 Dimension table GLYCODUR® RS bushings**

**3**

GLYCODUR®  
RS

Dimension			Mass	Designation
d	D	B		
mm	mm	mm	g	
5	7	5	0.70	<b>PG 050705 RS</b>
	7	8	1.10	<b>PG 050708 RS</b>
6	8	6	1.00	<b>PG 060806 RS</b>
8	10	8	1.70	<b>PG 081008 RS</b>
	10	12	2.50	<b>PG 081012 RS</b>
10	12	10	2.50	<b>PG 101210 RS</b>
	12	15	3.80	<b>PG 101215 RS</b>
	12	20	5.10	<b>PG 101220 RS</b>
12	14	10	3.00	<b>PG 121410 RS</b>
	14	12	3.60	<b>PG 121412 RS</b>
	14	15	4.50	<b>PG 121415 RS</b>
	14	25	7.60	<b>PG 121425 RS</b>
14	16	10	3.50	<b>PG 141610 RS</b>
	16	15	5.20	<b>PG 141615 RS</b>
	16	25	8.70	<b>PG 141625 RS</b>
15	17	15	5.60	<b>PG 151715 RS</b>
	17	25	9.30	<b>PG 151725 RS</b>
16	18	15	5.90	<b>PG 161815 RS</b>
	18	25	9.90	<b>PG 161825 RS</b>
18	20	20	8.80	<b>PG 182020 RS</b>
	20	25	11.00	<b>PG 182025 RS</b>
20	23	15	11.00	<b>PG 202315 RS</b>
	23	20	15.00	<b>PG 202320 RS</b>
	23	30	23.00	<b>PG 202330 RS</b>
22	25	15	12.00	<b>PG 222515 RS</b>
	25	20	16	<b>PG 222520 RS</b>
	25	30	25	<b>PG 222530 RS</b>
24	27	15	13	<b>PG 242715 RS</b>
	27	30	26	<b>PG 242730 RS</b>

Dimension			Mass	Designation	
d	D	B			
mm	mm	mm	g		
25	28	15	14.00	<b>PG 252815 RS</b>	
	28	25	23.00	<b>PG 252825 RS</b>	
30	34	20	30.00	<b>PG 303420 RS</b>	
	34	30	45.00	<b>PG 303430 RS</b>	
	34	40	60.00	<b>PG 303440 RS</b>	
35	39	20	34.00	<b>PG 353920 RS</b>	
	39	30	52.00	<b>PG 353930 RS</b>	
40	44	30	59.00	<b>PG 404430 RS</b>	
	44	50	98.00	<b>PG 404450 RS</b>	
45	50	30	83.00	<b>PG 455030 RS</b>	
	50	50	140.00	<b>PG 455050 RS</b>	
50	55	30	93.00	<b>PG 505530 RS</b>	
	55	60	185.00	<b>PG 505560 RS</b>	
55	60	40	135.00	<b>PG 556040 RS</b>	
	60	65	40	145.00	<b>PG 606540 RS</b>
		65	60	220.00	<b>PG 606560 RS</b>
60	65	70	255.00	<b>PG 606570 RS</b>	
	70	75	50	210.00	<b>PG 707550 RS</b>
75		70	300.00	<b>PG 707570 RS</b>	
75	80	80	365.00	<b>PG 758080 RS</b>	
80	85	60	290.00	<b>PG 808560 RS</b>	
	85	100	485.00	<b>PG 8085100 RS</b>	
85	90	100	510.00	<b>PG 8590100 RS</b>	
	90	95	60	325.00	<b>PG 909560 RS</b>
95		100	540.00	<b>PG 9095100 RS</b>	
95	100	100	570.00	<b>PG 95100100 RS</b>	
100	105	60	360.00	<b>PG 10010560 RS</b>	
	105	115	690.00	<b>PG 100105115 RS</b>	

Delivery of special shapes and sizes on request if the batches are large enough to be economical.

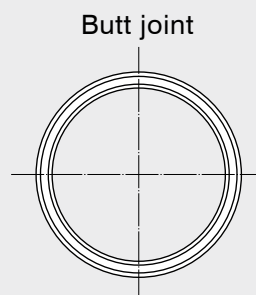
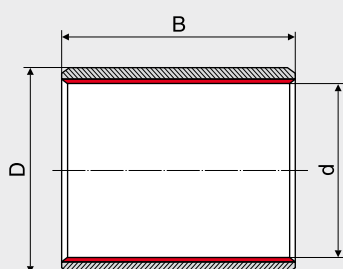

# 4

## 4.1 Applications GLYCODUR® RB and GLYCODUR® RS

- Engineering
- Precision engineering
- Valves
- Chemical apparatus engineering
- Medicine and laboratories
- Pumps
- Household equipment
- Food industry
- Pharmaceuticals
- Ship and boat construction
- Convertible roofs...



**GLYCODUR®**





GLYCODUR®  
Dry Bearings  
Catalogue



GLYCODUR®  
RPL and RPH



**Federal-Mogul Wiesbaden GmbH & Co. KG**

Postfach 13 03 35 · D-65091 Wiesbaden · Stielstraße 11 · D-65201 Wiesbaden

Tel. +49 (0)611/2 01-91 30 · Fax +49(0)611/2 01-91 38

info@glycodur.de · www.glycodur.de