

THIS DOCUMENT IS THE EXCLUSIVE PROPERTY OF FEDERAL-MOGUL / GLYCO. ALL RIGHTS, INCLUDING PATENTS, TRADEMARKS AND LEGAL CLAIMS ARE RESERVED. NO RIGHTS ARE TRANSFERRED OR ABANDONED BY FEDERAL-MOGUL / GLYCO WHEN SUBMITTING THIS DOCUMENT. ANY DUPLICATION, TRANSFER, RECORDING OR ANY OTHER USE FOR INTERNAL OR EXTERNAL PURPOSES NEEDS THE PRIOR EXPRESSED WRITTEN CONSENT OF FEDERAL-MOGUL / GLYCO.

Dieses Dokument ist Geschaefts- u. Betriebsgeheimnis von FEDERAL-MOGUL / GLYCO. Alle Rechte daran u. daraus, insbesondere Patent- Marken- u. Gebrauchsmusterrechte sind vorbehalten. Mit der Uebergabe werden von FEDERAL-MOGUL / GLYCO keine Rechte uebertragen oder aufgegeben. Jede Vervielfaeltigung, Weitergabe, Speicherung oder sonstige Nutzung zu eigenen oder fremden Zwecken bedarf der Zustimmung von FEDERAL-MOGUL / GLYCO.

ONLY FOR INFORMATION - WITHOUT ENGAGEMENT OR WARRANTY / Nur zur Information - ohne Gewaehr und Garantie
 SUBJECT TO CHANGE / Aenderungen vorbehalten

NOT SCALED! Nicht maszstaeblich!

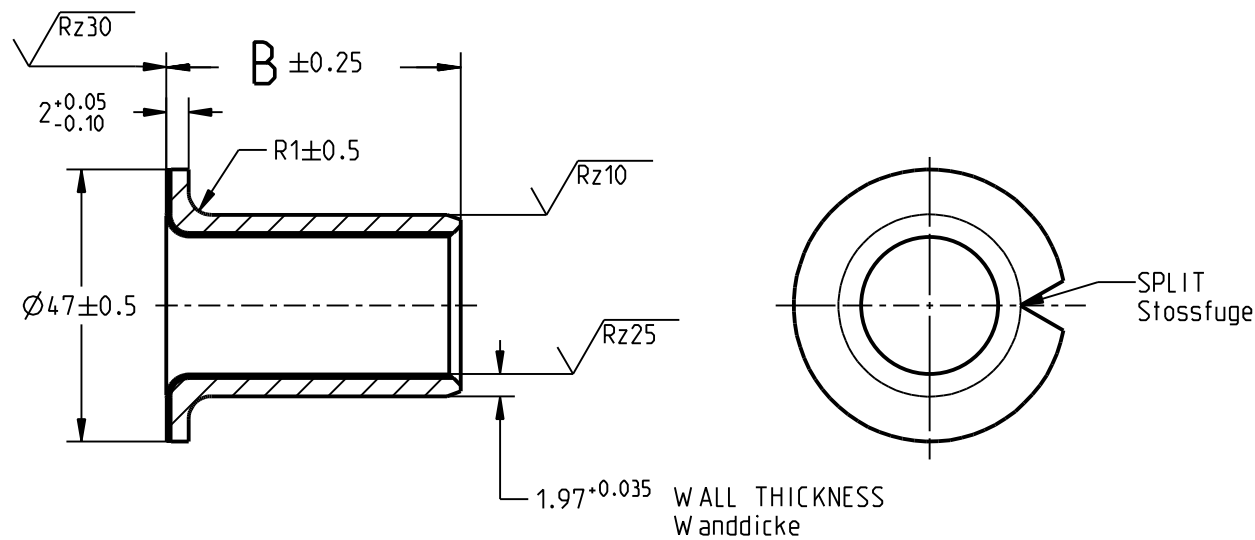

DESIGNATION Bestellbezeichnung	B (mm) WIDTH Breite	(g) WEIGHT CALCULATED Gewicht errechnet
PBG 35 39 26 F	26	61
PBG 35 39 16 F	16	43
HOUSING BORE / Gehaeusebohrung	=	∅39 H7 (39.000 / 39.025)
SHAFT / Welle	=	∅35 f7 (34.950 / 34.975)
CLEARANCE / Spiel	=	0.015 / 0.135

INSTALLATION REFERENCE SEE CATALOG / Einbauhinweise siehe Katalog

MATERIAL: Werkstoff: GLYCODUR F G-92 verzinkt TIN PLATED	SURFACE FINISH / Oberflaechen $\sqrt{Rz100}$ ($\sqrt{\quad}$) ISO 13715	ISO 1302 - 2002 DEFORMATION DUE TO FORMING PERMISSIBLE. Verformungen durch das Rundbiegen sind zulaessig.
--	--	--

	FEDERAL MOGUL GLYCO © Federal-Mogul. All rights reserved	NORMPROGRAMM
---	--	---------------------

REVISION DATE Revisionsdatum 21.10.16	PART NAME Benennung BUSHING Buchse	DRAWING NO. Unterlagen-Nr. TAB PBG 35 39 F
--	---	---